



Installation and Set Up Instructions

Superfy Pro Fill Level Sensor

Contents

	Welcome	3
	Introduction	4
	Device Connectivity	7
	Before you start	8
	Install the Superfy App	9
	Download the latest version of the Superfy App onto your mobile phone/tablet:	9
	Turning on the Superfy Pro Fill Level Sensor	10
01	Measuring Fill Height and Fill Gap for Superfy Pro Fill Level Sensor	11
	Superfy Pro Device Fitment - Standard Bracket	11
	Superfy Pro Device Fitment - Adjustable Bracket	12
02	Installation of Superfy Pro Fill Level Sensor	13
	Standard Bracket Installation	13
	Optional sidewall Bracket Installation	17
	Optional adjustable Bracket Installation	20
03	Add a Container to the Map Using the Superfy App	23
04	Allocate a Superfy Pro Fill Level Sensor to a Container using the App	29
05	Add Images to a Container using the Superfy Mobile App	36
06	Superfy Pro Manual Reading	41
	Checking a Manual Reading on the Superfy App	42
	Checking a Manual Reading on the Web Platform	45
07	Cleaning the Superfy Pro Fill Level Sensor and Bracket	47
	Maintenance	47
08	Warranty and RMA	48

Welcome

This guide offers detailed instructions for installing the **Superfy Pro Fill Level Sensor**, along with information on the device specifications, key features, the best installation practices and troubleshooting tips. It is recommended to use this guide in conjunction with the **Installation Checklist** for a smooth and successful installation of the Superfy Pro Fill Level Sensor.

This guide will help you get connected as quickly and easily as possible.

Introduction

The **Superfy Pro Fill Level Sensor** is designed and engineered to withstand the harsh waste and recycling environmental conditions. It effectively tracks and gathers data on the current Fill Level and Temperature of any type of container. This information is then transmitted to the **Superfy Platform**, which allows you to easily monitor, analyse, and manage your waste and recycling lifecycle. Ideal for smart cities, commercial waste and recycling collectors, construction sites, estates and parks, campuses and shopping malls or any application that requires waste and recycling management.

The Superfy Pro Fill Level Sensor is equipped with dual **Optical Sensors**. When properly installed, with the optical sensors facing downwards towards the centre bottom of the container, the Superfy Pro Fill Level Sensor accurately calculates the current percentage of the container's fill level. To determine the current fill level percentage, the Superfy Pro Fill Level Sensor calculates the average distance between the nearest object to sensor 1 and the nearest object to sensor 2. The dual optical sensor implementation provides accurate distance and fill level sensing capability, up to 5 m. The robust enclosure includes a long-lasting battery and cellular connectivity options for **LTE CAT-NB1** and **CAT-M1**.

Ultrasonic Sensor*

Capture the topology of the contents in the container

Long battery lifetime

Up to 5 years

IP66 Rated

Enables submersion for short time

Hardened Plastic Enclosure

Hardened plastic enclosure allows for robust installation in harsh environments

Multiple Connectivity

LTE CAT-NB1 or CAT-M1

Dual Optical Sensors

For accurate distance and fill level measurements

Activation Port

Magnetic activation

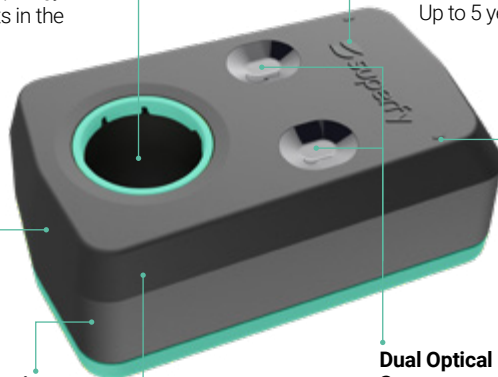

*Ultrasonic sensor is available as an optional extra.

Key Features

- Multi-technology distance sensing up to 5 m
- Accurate, real-time fill level and temperature sensing
- Sensing suitable for containers of various sizes, shapes and materials
- Multiple connectivity options - LTE CAT-NB1 or CAT-M1
- Long lasting, replaceable dual lithium-thionyl chloride (Li-SOCL₂) batteries
- Emergency alerting system for high temperatures and overflowing containers
- IP66 rated for harsh waste environments

SPECIFICATIONS

Physical

Weight (batteries included /excluded)	358 g /165 g
--	--------------

Dimensions	129 x 74 x 50 mm (L x W x H)
-------------------	------------------------------

Turn on mechanism	Magnetic
--------------------------	----------

Power

Batteries voltage and capacity	3.6V, 2600 mAh
---------------------------------------	----------------

Batteries type	Lithium-thionyl chloride (Li-SOCL ₂)
-----------------------	--

Battery replaceable	Yes, 2 batteries type LS14500 (2 x 54 grams)
----------------------------	--

Environmental

Temperature	-30°C ~ 70°C (Test Standard: IEC60068-2-1 & 2)
--------------------	--

Relative Humidity	25 ~ 55°C / 55 ~ 95% RH (Test Standard IEC60068-2-30)
--------------------------	---

Storage Temperature	-30°C ~ 60°C
----------------------------	--------------

Storage Relative Humidity	10 ~ 90% RH
----------------------------------	-------------

IP Rating	IP66
------------------	------

Note: For optimal battery life, we recommend a heartbeat of every 6 hours or more.

Note: When installing the sensor, both optical lenses must be positioned facing downwards towards the centre bottom of the container. If one of the optical lenses is directed towards the side of the container or any other direction, it can result in inaccurate data readings.

Dimensions

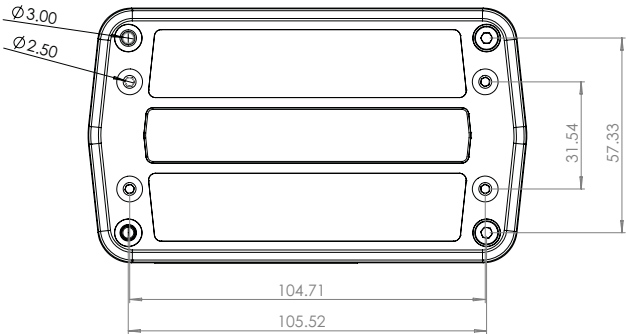
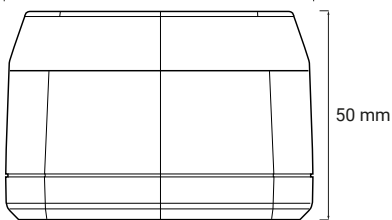
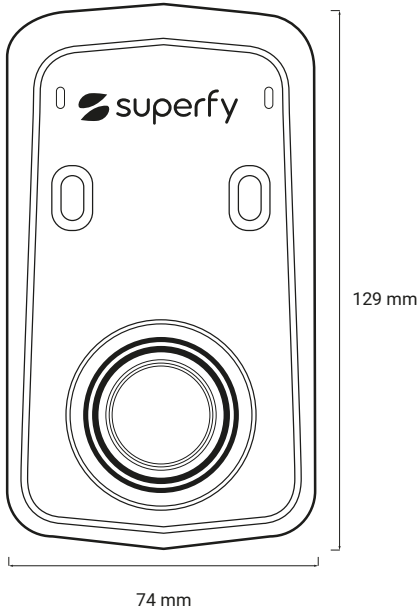

Device Connectivity

The device will auto connect to the preferred network of the SIM provider. Lower signal levels will result in reduced battery life.

Before you start





To get started with your **Superfy Platform** account setup and installation of the **Superfy Pro Fill Level Sensor**, please make sure to:

- Download the **Installation Checklist**
- Fill out the **Container Information Template**

Note: To complete the platform onboarding process, please fill out this form and return it via email to your **Superfy Customer Success Manager** or support@superfy.com. Only complete and submit this form if you have not already done so.

- Email the forms to your customer success manager, or support@superfy.com

Minimum Tools Required

 Screwdrivers PH2, PH1	 Container Key(s) (if required)
 Drill	 Torque driver,
 Laser Measuring Tool (recommended)	 3 mm Hex
 Magnet*	 Cleaning Wipes

* A **Strong Magnet** is required to activate and deactivate the Superfy Pro Fill Level Sensor, or to conduct a manual reading.

To reduce waste, Superfy no longer includes a magnet with each Superfy Pro Fill Level Sensor that is shipped.

Superfy have provided magnets with orders in the past, however, in line with our sustainability programme, we encourage our customers and partners to use any suitable strong magnet to activate, deactivate or to conduct a manual reading of the Superfy Pro Fill Level Sensor.

Install the Superfy App

Download the latest version of the Superfy App onto your mobile phone/tablet:

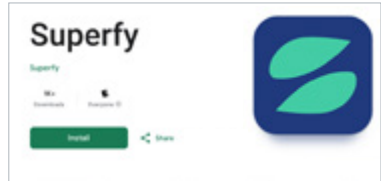
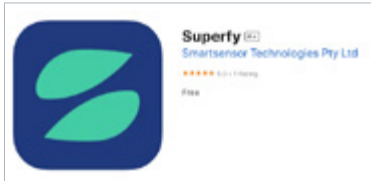

Apple users –

Please download the **Superfy App** from the [APP Store](#)

OR

- Log into your **App Store**.
- Search for **Superfy** using the **Search Bar**.
- Select **Superfy** and tap **Install**.

Android users –

Please download the **Superfy App** from the [Google Play Store](#)

OR

- Log into your **Google Play Store**.
- Search for **Superfy** using the **Search Bar**.
- Select **Superfy** and tap **Install**.

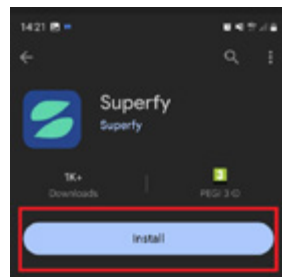
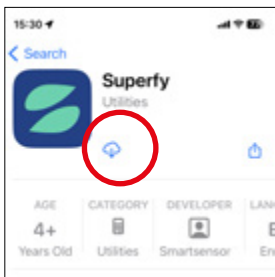

! Ensure to download the Superfy App NOT the *Superfy Tracker App

Login is the same login as you were initially set up with

Don't have a login?

Please reach out to your **Company Admin, Account Manager, Customer Success Manager**, or [email support@superfy.com](mailto:email.support@superfy.com).

They will be able to assist you in creating a login for your account.

Turning on the Superfy Pro Fill Level Sensor

! Turn on the sensor immediately before installation

TURNING ON

Hold a strong **Magnet*** at either of the activation ports as illustrated below.

Listen for 5 beeps, followed by an **up-tone sound**. After a few minutes, you will hear a **second up-tone sound**, indicating that the data is now successfully being sent to the cloud.  **Listen here:**

TURNING OFF

To turn off the device, place the **Magnet** at either of the activation ports. After approx. 3-4 seconds the device will begin to **beep 5 times**, followed by a **long beep**, then **silence**. The device is now off.  **Listen here:**

Note: Turning off the sensor will not take any readings from the container

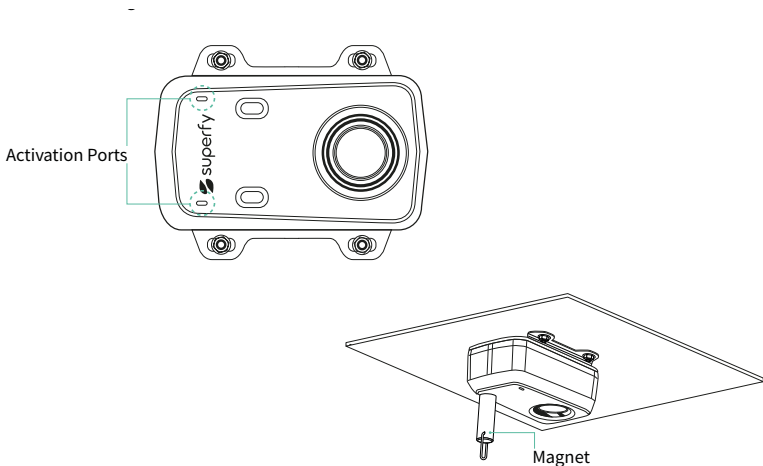

Note: The Superfy Pro Fill Level Sensor is pre-installed with batteries and a SIM card for your convenience.

Only Turn On the sensor after assigning it to a container on Superfy App. This will let you view data instantly and take manual readings

Note: The device will auto connect to the programmed cellular network option in the SIM. Lower signal levels will result in reduced lifetime of the device.

Note: As soon as the sensor is activated, it will begin consuming battery power.

01

Measuring Fill Height and Fill Gap for Superfy Pro Fill Level Sensor

Superfy Pro Device Fitment - Standard Bracket

For accurate container fullness levels:



Before you go on site to install your Superfy Pro Fill Level Sensor in a **Container** the ***Capacity or Volume** of each **Container** must be correctly recorded on the **Container Information Template**.



The **Fill Height** and **Fill Gap** must be recorded during installation on the **Superfy App**.

Please ensure to save the **Fill Height** and **Fill Gap** measurements, as you will need these measurements when assigning a sensor to its container in the Superfy App. This will be covered in more detail later in **Sections 3 & 4**.

FILL GAP: Measure the distance from the face of the Superfy Pro Sensor to the top of the internal container. This is the **Fill Gap**.

FILL HEIGHT: Measure the distance from the top of the internal container to the base of the internal container (**i.e. to where the container will be considered '100% full'**). This is the **Fill Height**.

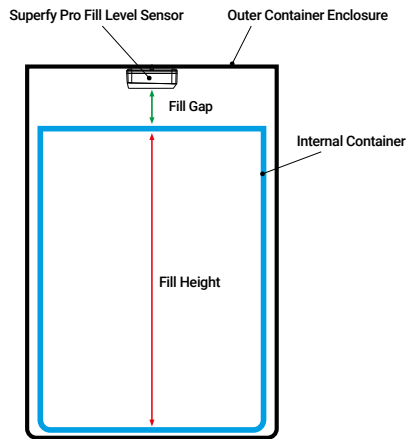

Note: If these measurements are not accurate, you will receive incorrect fill level data.

*Container capacity refers to the measurement of the container volume or capacity which is typically included in the container specification manual or data sheet provided by the container manufacturer. Additionally, you may be able to find the volume or capacity measurements on the manufacturer's website.

Superfy Pro Device Fitment - Adjustable Bracket

Measure the installation position

Measure the **Internal Height (Y)** and **Width (X)** of the container. If the container height (Y) of the back wall is less than the container width (X), install the sensor in **Position 1**, if greater, install in **Position 2**.

The container sensor should be installed as close to the top edge of container as possible (**Z**), however, consideration needs to be made for access and fixings through the container wall, avoiding any hinges or obstructions.

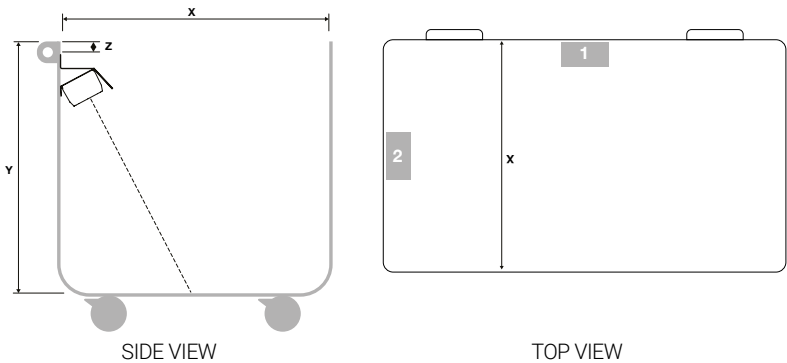

Fill Height is the measurement from the bottom of the container to where you establish 100% fullness (see **Red Line** below). The **Fill Gap** is the measurement from the sensor to the 100% fullness level. (see **Green Line** below).

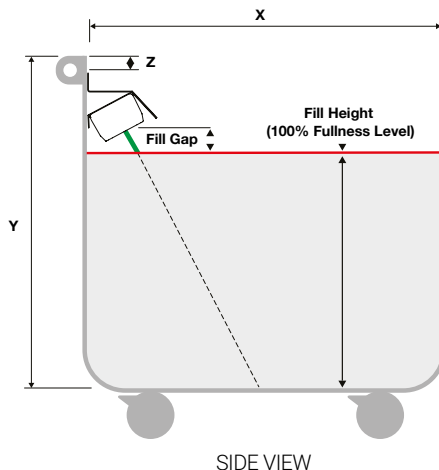

02

Installation of Superfy Pro Fill Level Sensor

Standard Bracket Installation

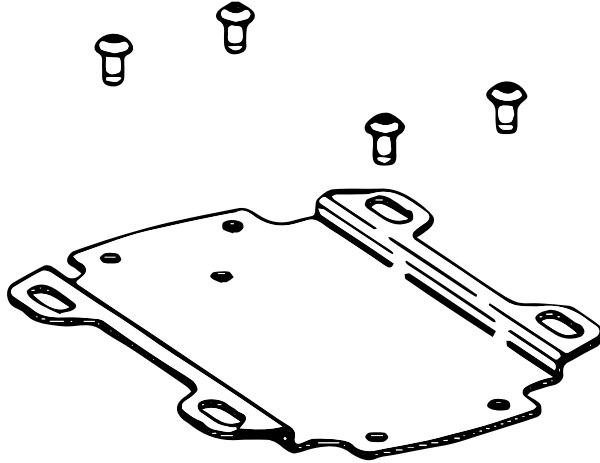

01 Measure and mark centre point

Measure the length and width of the container surround on the top of the container lid so that the centre point can be marked. Mark the centre point on the container surround with a marker.

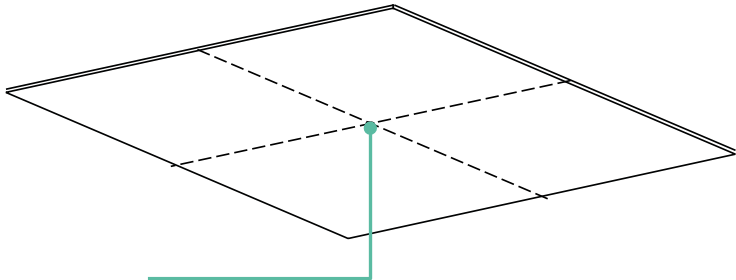

02 Align and mark Standard Bracket holes

Align the centre hole in the standard bracket with the centre mark and use this bracket as template to mark the 4 mounting holes in the centre of each slot. Ensure that the longer section of the standard bracket is oriented toward the rear of the container surround. Measure the length and width of the container surround on the top of the container lid so that the centre point can be marked. Mark the centre point on the container surround with a marker.

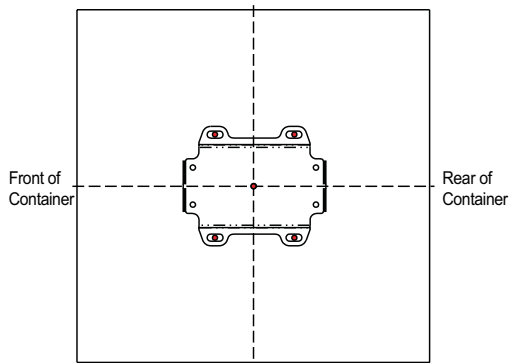
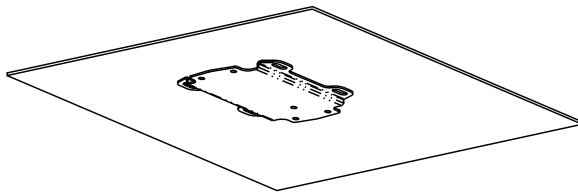

03 Drill bracket holes

Drill 4 x 4.5mm holes from the top of the container surround, as marked in Step 2.

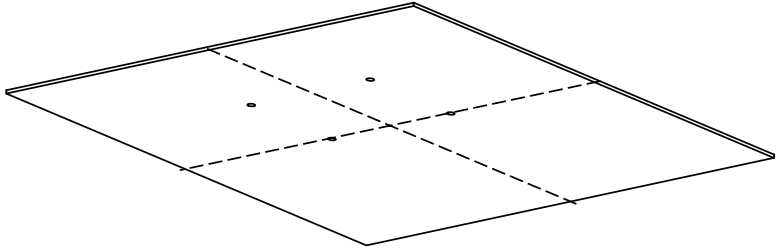

04 Fasten Standard Bracket to Superfy Pro Fill Level Sensor

Fasten the standard bracket to the Superfy Pro Fill Level Sensor using 4 x M4 x 6 Button Head Socket Screws.

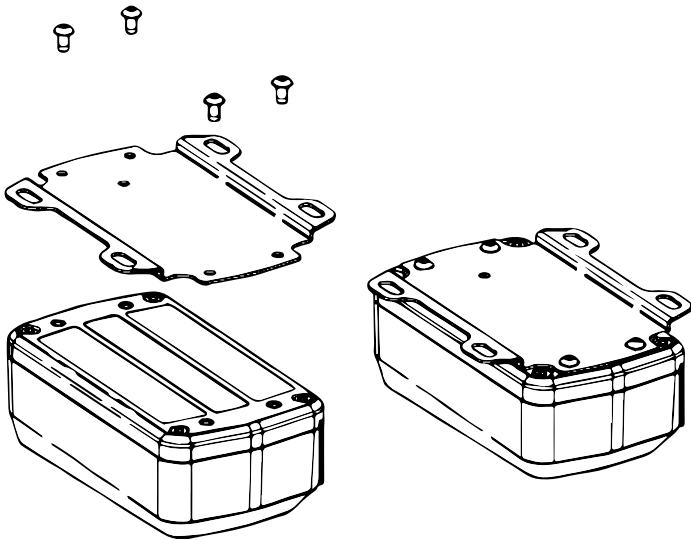

05 Loosely fasten Superfy Pro Fill Level Sensor to container surround

Loosely fasten the Superfy Pro Fill Level Sensor to the appropriate bracket. Attach the Superfy Pro Fill Level Sensor to the container using 4 x M4 x 10 ButtonHead Tamper Proof screws, 4 x M4 Washers and 4 x M4 Lock Nuts. The screw length may vary depending on the container surface thickness.

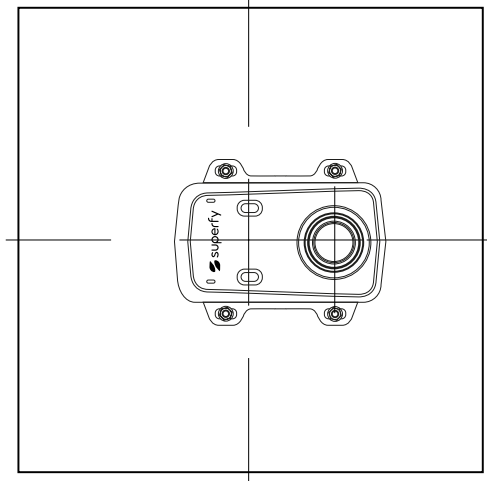
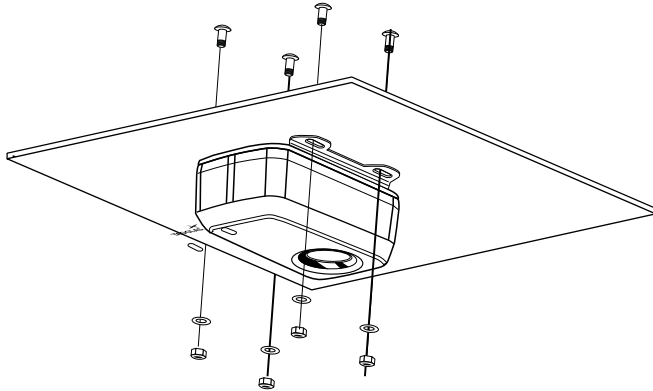

Optional sidewall Bracket Installation

Required Tools

M4 Allen Key	Cordless Drill
Measuring Tape	5 mm Drill Bit
Pencil / Marker	Tamper Proof Bit

Fixings

4 x M5 x 16* Tamper Proof Bolts
4 x M5 Lock Nuts
4 x M5 x 20 Washers

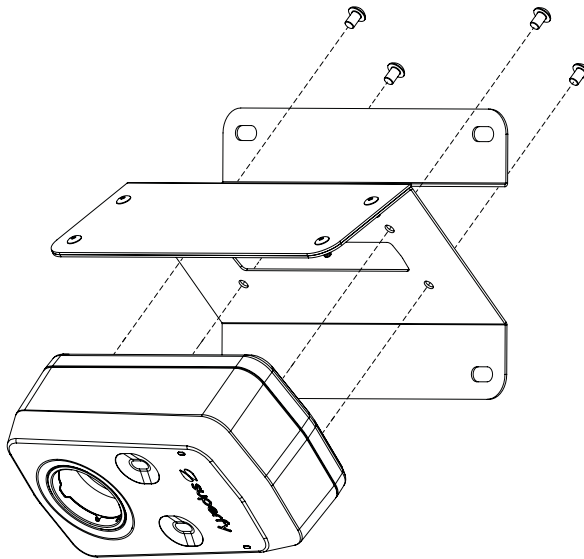

01 Attach the Superfy Pro Fill Level Sensor (if required)

Remove the Standard Bracket from the back of the Container Sensor. Using the same 4 x M4 x 6 button head socket screws, fasten the Container Sensor to the 45° mounting bracket as shown.

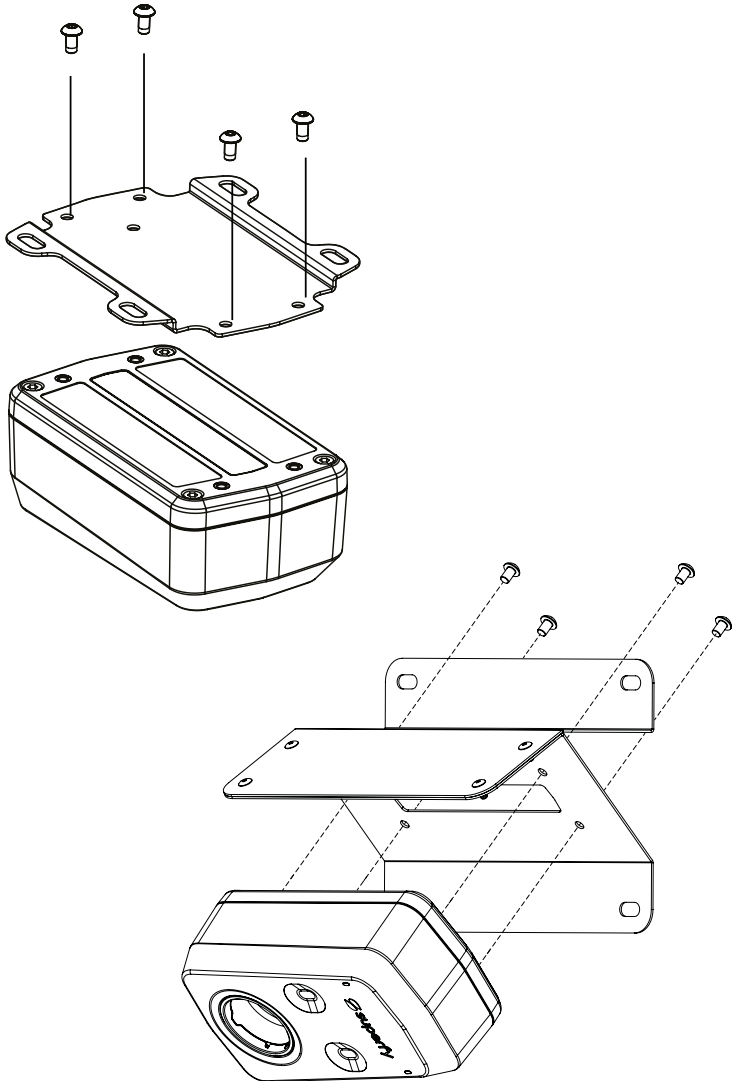

03 Drill bracket holes

Once the installation position has been determined, use the 45° mounting bracket to mark and drill 4 x 5 mm holes through the wall of the container. Ensure that the bracket remains level.

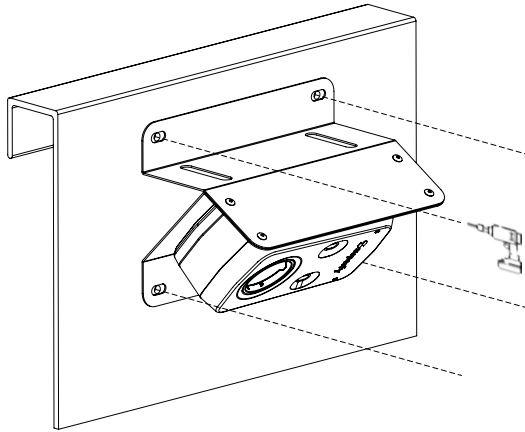

04 Fasten the Superfy Pro Fill Level Sensor

Fasten the sensor, with attached 45° mounting bracket, to the container wall using 4 x M5 x 16* Button Head Tamper Proof bolts, 4 x M5 x 20 Washers and 4 x M5 Lock Nuts.

***Bolt length is based on a container wall thickness of 4 - 8 mm, length may need to be changed for different wall thicknesses.**

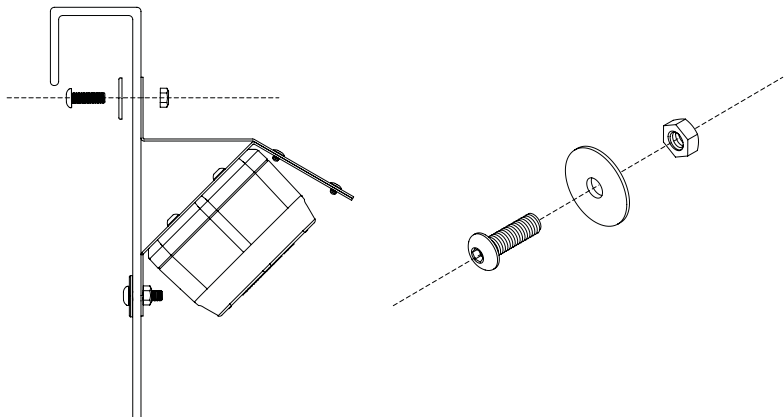

Optional adjustable Bracket Installation

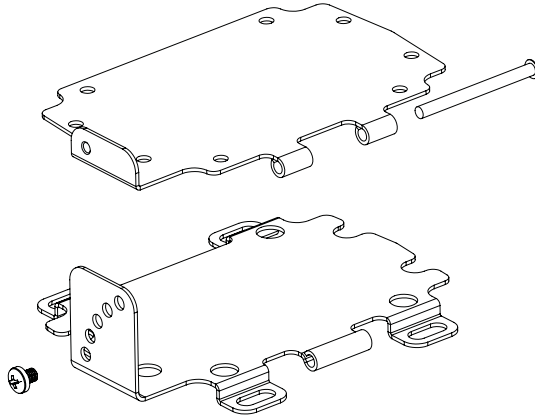

01 Overview

Device angle fixing and mounting holes.

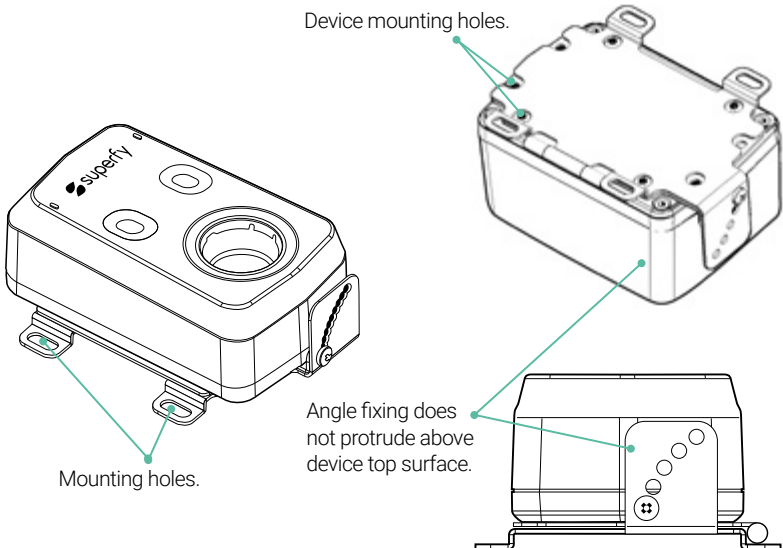

02 Adjustability option 1

Angle set by M4 screw installed in any of the holes.

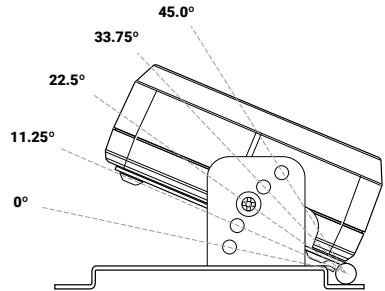
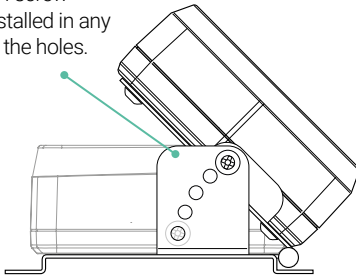

5 positions from 0° to 45° :

- Through-hole provides secure locking position
- Fixed positions prevent movement from vibration

03 Adjustability option 2

Angle set by M4 screw installed in any of the holes.

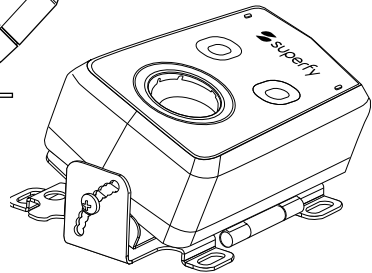
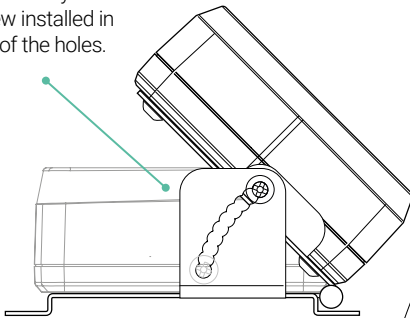

Hole positions every 5° from 0° to 45° :

- Slot with detents of increments of 50
- Fixed positions prevent movement from vibration

Screw needs to be removed when setting position.

04 Adjustability option 3

Angle set by M4 screw installed in slot clamping the tabs together.

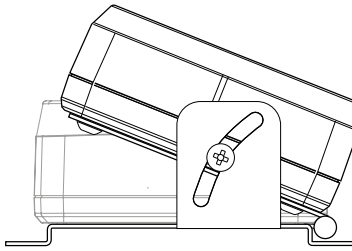
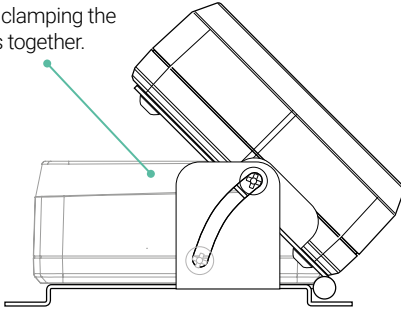

Infinitely adjustable from 0° to 45° :

- Bracket can be adjusted to the perfect angle
- Screw does not need to be removed during adjustment

Bracket may be susceptible to movement if the screw loosens over time.

03

Add a Container to the Map Using the Superfy App

This step is only necessary if the containers have **not been already added to their respective location on the Superfy Platform**. If the containers are already added, please skip to [Section 4](#) on how to Allocate a Superfy Pro Fill Level Sensor to a Container using the App.

There are 3 main container types within the Superfy Platform: a **Managed Container**, **QR Container** or a **Connected Container**. A Container can also have both a QR code and a Sensor associated to it.



Connected Container: these containers are **equipped with sensors** that enable them to deliver real-time data on their fullness and temperature levels. You have the flexibility to adjust the frequency at which the **G2 Fill Level Sensor** records the fullness readings from the container and transmits this information to the **Superfy Platform**.



QR Container: these containers are equipped with **QR Codes**, allowing the public or your direct customers to scan the code to request collections, report damages, contamination or litter, making the collection process more efficient and accessible for all involved parties. These containers do not display fullness level data either.



Managed Container: these containers are not equipped with a QR code or sensor. Instead, they operate based on collection threshold rules, making them suitable for locations that do not require frequent pickups. They do not provide data on fullness levels; rather, they employ a color-coded system that shifts between **Green**, **Orange**, and **Red** to indicate their status according to predefined **Intermediate and Maximum Collection Thresholds**.



QR and Connected Container - the best of both worlds, you can assign a **QR Code and a Sensor** to a container.

To facilitate a seamless installation process, it is essential for customers to complete the **Container Information Template** and submit it to their **Account Manager** or **Customer Success Manager**. This important step enables our **Customer Success team** to add the containers to their designated location on the map prior to the installation of the **Fill Level Sensor** or **Smart Container**.

Alternatively, the installation technician(s) has the option to utilise the **Superfy App** to complete this process while on-site.

Ensuring that the containers are placed in their designated locations on the map is crucial for a smooth installation process. This step allows the installation technician(s) to verify that the **Fill Level Sensors** are turned on, assigned to the appropriate containers, and recording accurate fill level data. It also helps in proactively troubleshooting any issues while on-site.

- Open the **Superfy App** on your phone.
- Your phone's GPS will show your current location as a **Blue Dot** on the map.

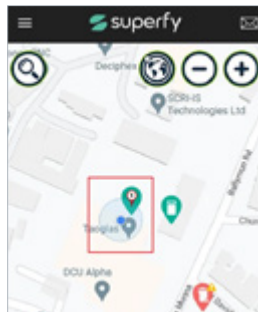

If adding a container remotely, use the **Magnifying Glass** (🔍) icon located in the top left corner of the **Map View** to search for the desired address for where you wish to place the container. **Choose Streets/Location** from the available search options when looking for specific addresses.

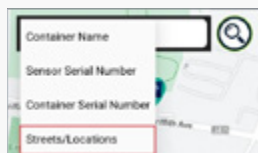

- At the bottom of your phone screen, tap on **Add Container** (👤) and tap on the location on the map where you wish to place the container.

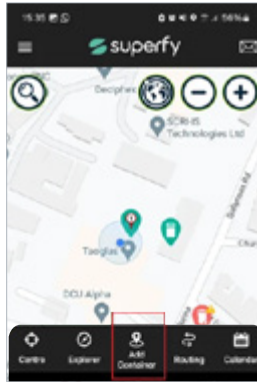

- Complete the below information on the **New Container Details** screen by selecting from available options or adding new items:
 - **Name** - use your preferred name for the container (**i.e. Container Identification Number**).
 - **Zone** - choose the **Zone** where you wish to place the container.
 - **Icon** - choose your preferred icon from the available list of container icons.

A **Zone** is a defined set of containers, often corresponding to the customer's own segmentation of their city.

- **Images** - It is required to add photos during the installation of the **Fill Level Sensor** or **Smart Containers**.

- Include clear and detailed photos showcasing the installation of the sensor, providing a visual representation of where and how the sensor was installed.
- Photos of the **container (type, Container Identification Number etc.)**
- Include clear and detailed photos that showcase the environment surrounding the container. These photos will provide a visual representation of the area where the container is located, helping to provide context and a better understanding of its surroundings.

- Tap on **Camera Image** (📷) to take and add a photo.
- **Add Title** (i.e. container name).
- **Add Description** - this is optional!
 - Tap **Done**.
- Tap **Save**.



You can only upload One photo during the initial container creation. However, you can add additional photos once the container has been successfully created and added to the platform. This will be covered later below.

- **Subscription Type** - choose the container subscription type by sliding the toggle next to your preferred option: QR Container, Connected Container, or both. Please be aware that the Managed option will be selected by default.
- **Container Type** - choose the appropriate container type from the available options in the list.
- **Container Tags** - this is optional. You can add any additional tags of your choice to a container.
- **Waste Type** - select the appropriate waste material.
- **Account** - select the appropriate account associated with the container.
- **Location** - select the appropriate location associated with the container.

Please note to allocate a sensor, the **Connected Container Subscription Type** must be enabled. When this is enabled, you are required to allocate a sensor to the container as the next step.

When you select the **Connected Container** option for a container and save it, **this cannot be changed** on the app. This can only be changed on the platform.

- If you have selected the **Connected Container** subscription type, tap **Next** to allocate a sensor. Otherwise, tap **Save** to add the container to the platform.
 - On the **Connected Container** screen, tap on **Sensor Name** to search and allocate a sensor.
 - Select the **Sensor** from the list of available sensors or use the search bar to search for the sensor.
 - Tap on the sensor and tap **Done**.
 - Enter the accurate fill height on the **Fill Height** field.
 - Enter the accurate fill gap on the **Fill Gap** field.
 - Tap **Save**.

If the sensor is turned **ON**, the **Container Icon** () will change colour accordingly from **Grey** to one of the below depending on the fullness level recorded by the sensor or the applied **Intermidate** or **Max Threshold**.



- To take and add more photos:
 - Tap on the **Container** (🗑️) on the map view.
 - Tap on **View**.

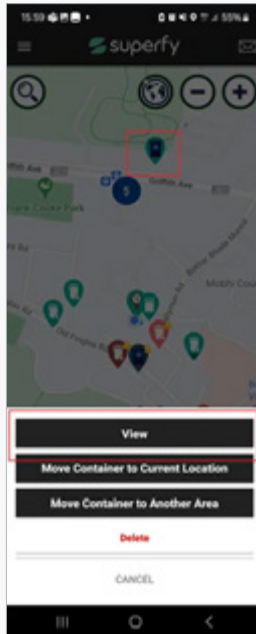

- On the **Container Details** screen, scroll down to **Images** again and tap on it.
- Tap **Plus (+)** icon to take and add more photo
- Tap **Save**.
- Tap the Back (⏪) button located at the top left-hand side of the screen to add more photos and repeat the same steps by clicking the **Plus (+)** icon again if necessary.



- Tap the **Back** (⏪) button once more to update the Container Details.
- Tap **Next**.
- Tap **Save Container**.

04

Allocate a Superfy Pro Fill Level Sensor to a Container using the App

To accurately monitor the current **Fill Level and Temperature** of a container, it is essential to install, activate, and assign a Superfy Pro Fill Level Sensor to the container.

To ensure a smooth installation process, we highly recommend **Turning ON** the **Superfy Pro Fill Level Sensor** and allocating it to the container just before installation.

Make sure to verify that the correct **Identification Number** of the Superfy Pro Fill Level Sensor has been assigned to the container. The **Identification Number** of the **Superfy Pro Fill Level Sensor** can be found on the side of the sensor, right next to the **QR Code**.

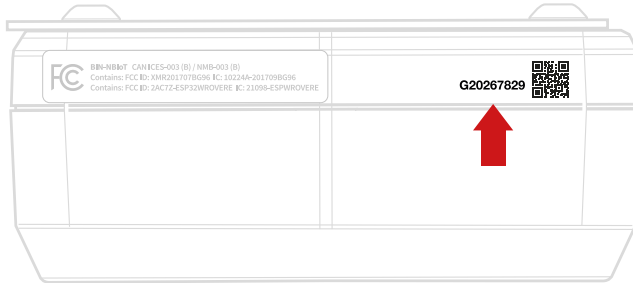

[Learn how to Turn ON the Superfy Pro Fill Level Sensor](#)

- Open the **Superfy App** on your phone.
- Your phone's GPS will show your current location as a **Blue Dot** on the map.



- Tap on the **Container** displayed at your current location on the **Map**, then tap on the **View** option.

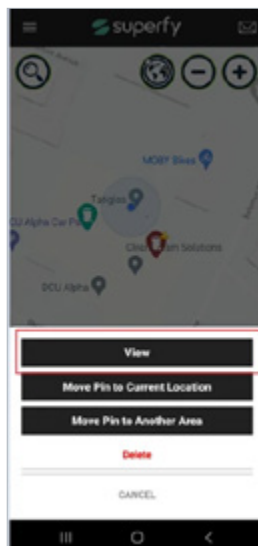

If you're not at the container's location, use the **Magnifying Glass** (🔍) located at the top left-hand side in the **Map View** to search by **Container Name**, **Sensor Serial Number**, **Container Serial Number** and **Street/Location**.

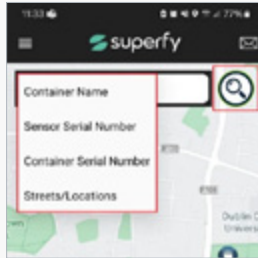

Alternatively, you can tap on **Explorer** (📍) located at the bottom of the screen. This will provide you with a comprehensive list of all the **Containers** available for viewing.

- Tap on the **Container** of your choice.

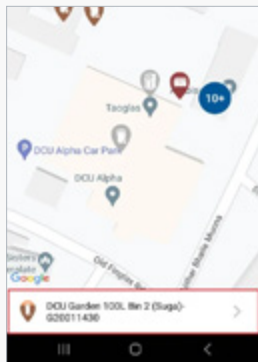

- Tap on the **Arrow** beside the **Container Name** at the bottom of the screen to open the **Container Details** screen.

- On the **Container Details** screen, scroll down to the **Sensor** field and tap.

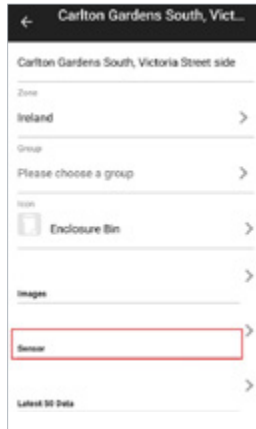

Before you allocate a new sensor to a container, you must first detach any sensor that is currently assigned to it. **A container can only have one sensor assigned at a time**, so this step is essential for a successful installation.

If a sensor is currently not allocated to the container, skip the below.

- Tap on the **3 dots** beside the **Sensor ID Number**.



- Tap on **Detach Sensor** to detach the sensor from the container.
- Tap **Okay** on the below pop-up message.

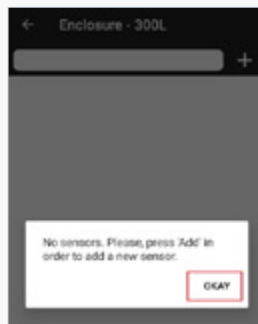

- To add a new **Sensor**, tap the **+** icon.

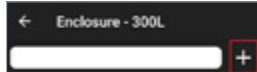

- Tap on **Sensor Name** to search and allocate a sensor.
- Tap on **Select from List**.

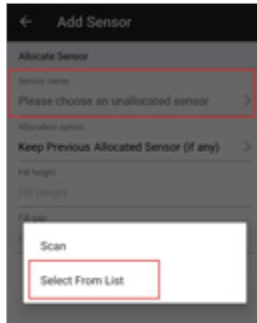

If you are unable to find the sensor in the list of available sensors, it is possible that the sensor has not been allocated to your account. In this case, please urgently reach out to your **Account Manager**, **Customer Success Manager**, or contact support@superfy.com for assistance.

- Alternatively, search for the **Sensor ID Number** using the **Search Bar**.
- Tap on the **Sensor ID Number** to allocate it to the container and tap on **Done**.



- Enter the accurate **Fill Height** and **Fill Gap** measurements.



Refer to **Section 01** on how to take the **Fill Height** and **Fill Gap** Measurement.

- Tap on **Allocate** to allocate the sensor to the container.



- Tap on **Back** (←/↶) to return to the **Container Details** screen.



- Tap on **Next** located at the bottom of the screen.

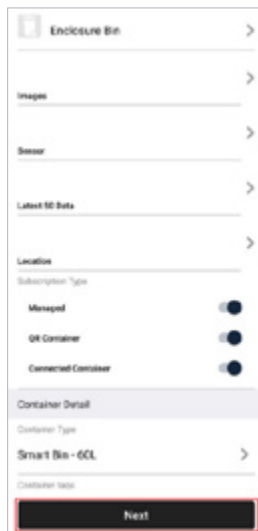

- Tap **Save Container** to update the **Container Details**.

- After saving the container, tap **Okay** on the pop-up message.

If the sensor is turned **ON**, the **Container Icon** () will change colour accordingly from **Grey** to one of the below depending on the fullness level or the applied **Intermidate** or **Max Threshold**.



Mostly Empty (**Green**)



Partially Full (**Orange**)



Mostly Full (**Red**)

Before leaving site, it is crucial to:

Take a **Manual Reading** to ensure that the sensor is turned on and transmitting data to the platform. Confirm that the date and timestamp are accurate, and compare the container's fill level with the actual contents of the container. This step is important to ensure accurate monitoring and management of the container. This will be covered later in **Section 6**.

05

Add Images to a Container using the Superfy Mobile App

Including detailed images of the sensor's installation inside a Container and its surroundings is crucial for troubleshooting and strongly recommended.

When installing a sensor in a **Container**, it is crucial to:

- Include clear and detailed photos showcasing the installation of the sensor, providing a visual representation of where and how the sensor was installed.
- Photos of the **Container (type, ID number etc.)**
- Include clear and detailed photos that showcase the environment surrounding the **Container**. These photos will provide a visual representation of the area where the **Container** is located, helping to provide context and a better understanding of its surroundings.

- Open the **Superfy App** on your phone.
- Your phone's GPS will show your current location as a **Blue Dot** on the map.

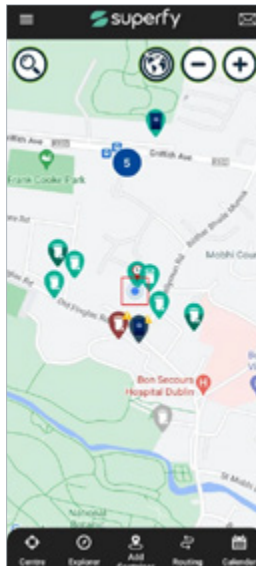

- Tap on the **Container** displayed at your current location on the **Map**, then tap on **View**.

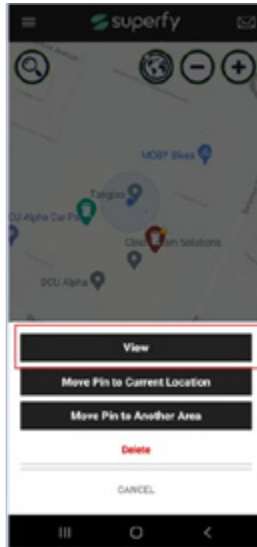

If you're not at the container's location, use the **Magnifying Glass** (🔍) on the left-hand side of the **Map View** to search by **Address**, **Container Name**, **Container Serial Number**, or **Sensor Serial Number**.

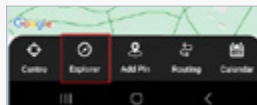

Alternatively, you can tap on **Explorer** (🔍) located at the bottom of the screen. This will provide you with a comprehensive list of all the **Containers** available for viewing.

- Tap on the **Container** of your choice.

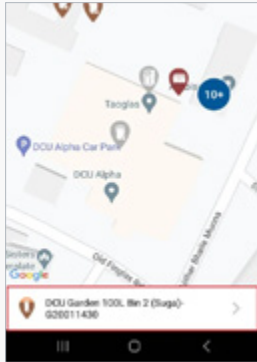

- Tap on the **Arrow** beside the **Container Name** to open the **Container Details**.

- On the **Container Details** screen, scroll down to **Images** and tap.

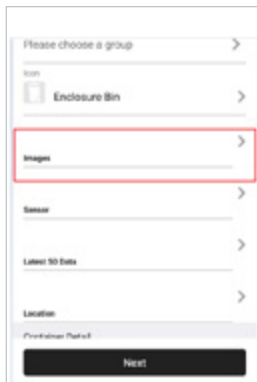

- Tap on the **Plus (+)** icon located on the top right-hand side of the screen.

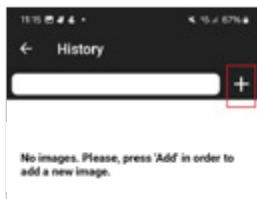

- Tap on **Camera Image** (📷) to take a photo.
- **Add Title** (ie: container name).
- **Add Description** - this is optional.
 - Tap **Done**.
- Tap **Save**.

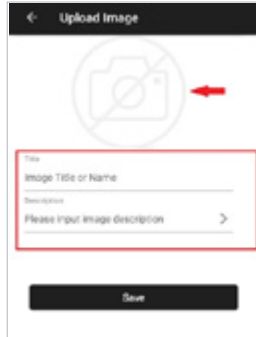

- You can only add **One** photo at a time. Once you have saved the initial photo,
 - Tap the **Back** (⏪) button once and tap on the Plus (+) icon again to add more photos.
 - Repeat the steps above until all photos are uploaded

- Tap on **Back** (⏪) to return to the **Container Details** screen.



- Tap on **Next** located at the bottom of the screen.

DCU alpha Garden

Group

Please choose a group

Enclosure Bin

Image

Sensor

Latest SD Data

Location

Container Detail

Asset type

Enclosure 130L

Access

Control Means

Weather

Weathered location

Remarks

Description

Manufacturer

Next

- Tap **Save Container** located at the bottom of the screen to update the **Container Details**.

Address Details

Default location

Default location

Address 1

Address 2

Address 3

Address 4

City

State

Country

Country

Post code

Post code

Latitude

Longitude

Longitude

Save Container

06

Superfy Pro Manual Reading

Taking a Manual Reading allows you to check if the Superfy Pro Fill Level Sensor is turned ON, receiving and transmitting data to the platform, and accurately recording the container's fullness level.

When installing the sensor, it is **crucial that you take a manual reading of the sensor to ensure that the fill level accurately reflects what's inside the bin.** If there's a discrepancy, double-check the fill height and fill gap measurements and make sure the sensor is correctly installed with both optical lenses facing downwards towards the center bottom of the container.

If one of the optical lenses is directed towards the side of the container or any other direction, it can result in inaccurate data readings.

Taking A Manual Reading

- Hold a strong **Magnet** at either of the activation ports highlighted in the below diagram until you hear **1 beep**.
- Remove the **Magnet** and you will immediately hear an **up-tone sound**.
- After a few minutes, you will hear a **second up-tone sound**, indicating that the data is now successfully being sent to the cloud.
- You can now view the manual reading data via the **Superfy Platform** or **App**

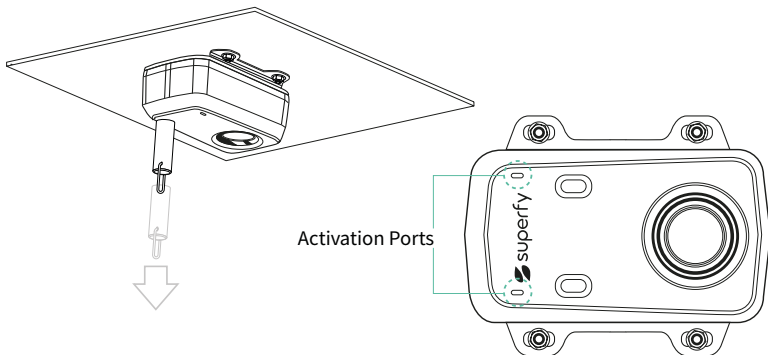

Checking a Manual Reading on the Superfy App

- Open the **Superfy App** on your phone.
- Your phone's GPS will show your current location as a **Blue Dot** on the **Map**.

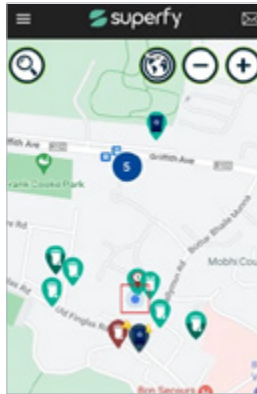

- Tap on the **Container** displayed at your current location on the **Map**, then tap on the **View** option

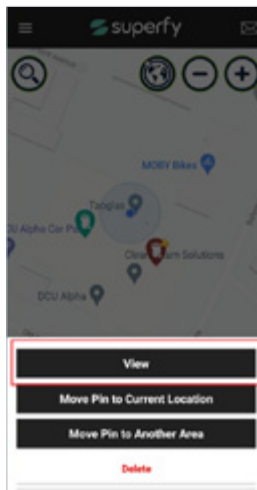

If you are not currently at the container's location, you can use the **Magnifying Glass** (🔍) on the left-hand side of the **Map View** to search for the **Address, Container Name, Container Serial Number** or **Sensor Serial Number** of the container to which you want to allocate a sensor.

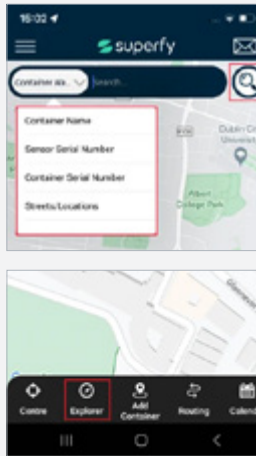

Alternatively, you can tap on **Explorer** (🔍) located at the bottom of the screen. This will provide you with a comprehensive list of all the Containers available for viewing.

- Tap on the **Container** of your choice.
- Tap on the **Arrow** beside the **Container Name** at the bottom of the screen to open the **Container Details** screen.

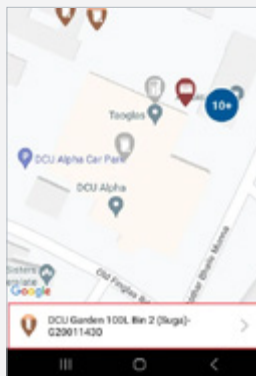

- On the **Container Details** screen, scroll down and tap on the **Latest 50 Data** to view the manual reading data.



- Check that the **Date and Time-stamp** matches the most current manual reading.
- Verify that the **Fill Level** matches what is physically in the container.

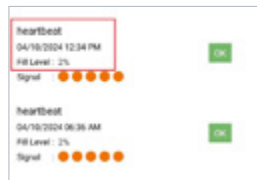

Checking a Manual Reading on the Web Platform

- Log into your **Superfy Account**.
- Click on the **Zone Explorer** (📍) icon located on the right-hand side panel.

You can also utilise the **Search** (🔍) icon located on the top left-hand side of the **Map View** and search by **Container Name** or **Serial Number**.

- On the pop-up screen, scroll down to **Containers**. You will find a comprehensive list of all the containers linked to your account. From here, you can search for and select the specific container you want to check the manual reading for.



- By clicking on a **Container**, you will be automatically directed to the container's location on the **Map**.
- Click on the **Container** icon (🗑️) on the **Map** to view the **Container Details**.

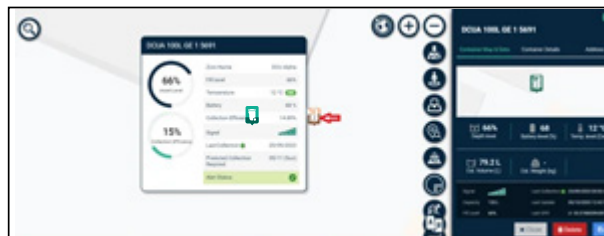

- On the right-hand side of the screen, scroll down and tap on the **Last 50 Data** to view the manual reading data.

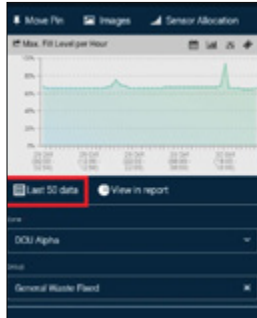

- On the pop-up screen, check that the **Date and Time-stamp** matches the most current manual reading.
- Verify that the **Fill Level** matches what is physically in the container.

If the **Fill Level** is incorrect, you may need to adjust your **Container Volume, Fill Height** or **Fill Gap** measurements.

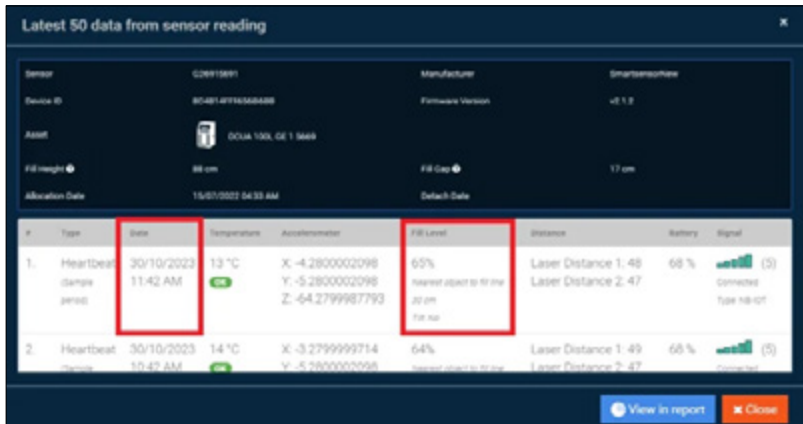

07

Maintenance

Superfy highly recommends regular cleaning of the sensor. This must be done with an eco-friendly cleaner.

Cleaning the Superfy Pro Fill Level Sensor and Bracket

Gently clean the two optical sensors with a clean cloth, no detergent required. Wipe over both the device and the bracket removing any dirt and grime from both surfaces. Do not spray cleaner directly onto the device. There is no need to remove the device from the container.

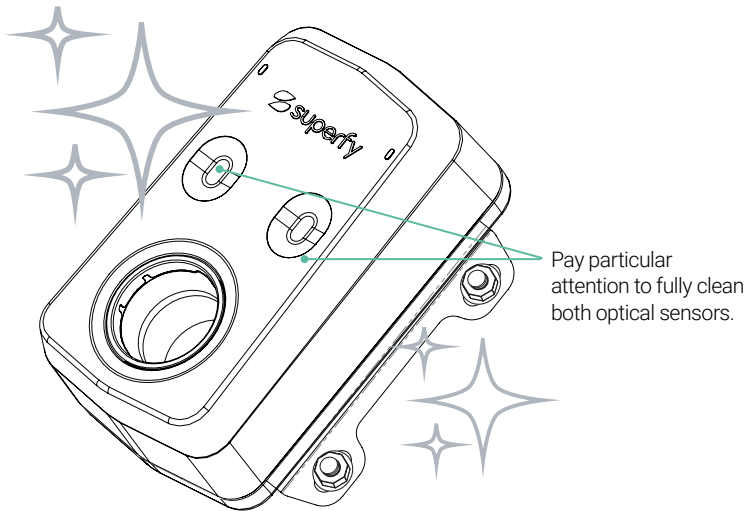

08

Warranty and RMA

The Superfy Pro Fill Level sensor has a 12-month warranty from the date of shipment of the Hardware to Customer during which Customer may perform Return Merchandise Authorization (RMA).

For products that are not covered under warranty, whether they are out of warranty or have subsequent defects, applicable charges for parts and services will apply. We recommend that customers consider the delivery costs before sending items for repair.

For more information on the RMA process please see:

<https://knowledge.superfy.com/knowledge/rma-process>

If you need any further assistance please contact:

support@superfy.com

